



CROOKED RIVER SERIES

Signature Models

JANUARY 2023

PRICE LIST



MOXWELDING
OFFROAD SOLUTIONS

CROOKED RIVER SERIES *Signature Models*

MOXWELDING
OFFROAD SOLUTIONS



Crooked River is here!

Moxwelding are proud to release their Signature Series of Offroad Touring solutions designed to make choosing a setup for your vehicle more refined.

Based on our vast experience with building customised solutions and our years of using the very products we design and build, we have developed 3 signature models covering a wide range of options.

Currently fitting to TOYOTA HILUX N70 & N80 DUAL CAB, TOYOTA 79 SERIES LANDCRUISER DUAL CAB, FORD RANGER DUAL CAB 2011 –CURRENT, NISSAN NAVARA NP300 DUAL CAB, ISUZU DMAX DUAL CAB 2012-2019, HOLDEN COLORADO DUAL CAB 2012-2020, MITSUBISHI TRITON DUAL CAB, MAZDA BT50

The Weekender

Designed for the weekend adventurer and day to day operator.
Maximum tray space with a small canopy for fridge and storage options.

The Getaway

Developed for the young couples and small families with a passion for regular getaways.
With majority canopy space combined with a small tray section.
The perfect blend.

The Breakout

For the avid adventurers! A full touring solution with all the essentials for extended travels.

All our builds are designed with a strict guideline for ease of use, functionality, and most importantly vehicle handling.
We want our customers to enjoy their time touring as much as we do.

CROOKED RIVER SERIES *Signature Models*



Experience, Development, Building Relationships

Over our journey of the past 10 years we have been fortunate enough to build some great Touring setups for customers that love to get out there and use them. A small family run business, some of our customers have become great friends of ours over the years and this is something we will never lose sight of.

We've had the privilege of building products for market leading companies and social media identities such as Brett from Crashpad Outdoor Gear, Sam Reed from Livin4x4, Raslarr Engineering, and more.

Seeing Photos and hearing the stories from our customers trips is fantastic and something we really look forward to.

Hopefully we will be seeing your pics and stories in the near future!



CROOKED RIVER SERIES

Signature Models

The Basecamp



- ALUMINIUM BASE TRAY 1700L x 1800W
- HEADBOARD WITH WINDOW PROTECTION INFILL
- 3MM RAW ALUMINIUM CHECKER PLATE FLOOR—REAR SECTION
- UPGRADED FILLER PORT
- INTERNAL TRAY TIE DOWN TRACK POINTS
- SIDE TAPERED TOOLBOXES
- FLARED ALUMINIUM GUARDS 50mm
- ALUMINIUM INFILLS WITH FILLER PORT UPGRADE
- LED MAXILAMP TAILLIGHTS W/ REVERSE FLOODLIGHTS
- SENSOR AND CAMERA ADAPTABILITY
- WHALE TAIL COMPRESSION LOCKS ON SIDE BOXES
- ELEMENT BLACK TEXTURE POWDER COAT, SAT-IN BLACK CNC PLATING

\$7995 inc gst—drive away

ADDITIONALS:

60 LITRE ALUMINIUM WATER TANK WITH 12V PUMP, PLUMBING,
WIRED TO VEHICLE BATTERY OR SUPPLIED AUX 12V

\$1195 inc gst

FULL SET ALUMINIUM TRAY DROP SIDES WITH ANTI RATTLE TRAY SIDE
LATCHES AND HEAVY DUTY ABS PLASTIC NO RUST NO RATTLE
HINGES

\$1195 inc gst

RELOCATE REVERSE CAMERA AND REVERSE SENSORS

\$275 inc gst

TUB REMOVAL AND DISPOSAL

\$275 inc gst

Add accessories from our list of upgrades,
such as colour matched toolbox doors, to
personalise your build



CROOKED RIVER SERIES *Signature Models*

Rear Side Mounted Radar Units

Radar units

All Vehicles fitted with side mounted radar units for blind spot awareness and lane assist can be fitted with radar adaptable brackets. Additional costs vary between makes and models. Please contact for additional information.



CROOKED RIVER SERIES

Signature Models

The Weekender

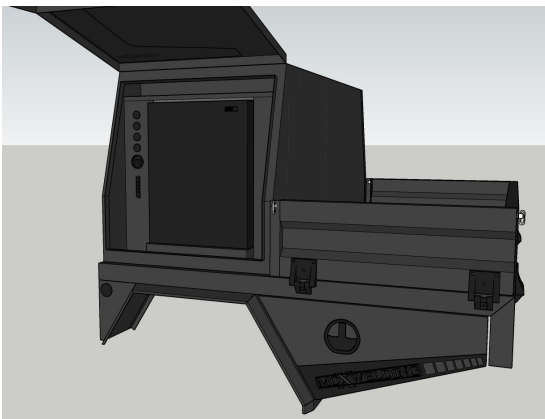
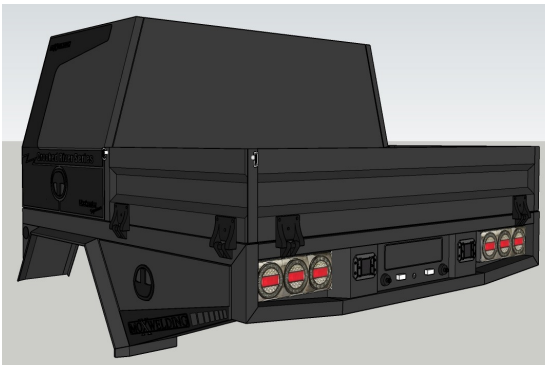
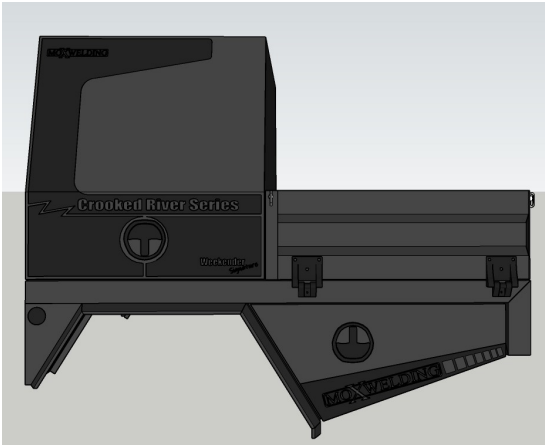

- ALUMINIUM BASE TRAY 1700L x 1800W
- 3MM RAW ALUMINIUM CHECKER PLATE FLOOR—REAR SECTION
- UPGRADED FILLER PORT
- TRAY DROP SIDES
- ANTI RATTLE TRAY SIDE LATCHES
- HEAVY DUTY ABS PLASTIC NO RUST NO RATTLE TRAY SIDE HINGES
- INTERNAL TRAY TIE DOWN TRACK POINTS
- SIDE TAPERED TOOLBOXES
- FLARED ALUMINIUM GUARDS 50mm
- ALUMINIUM INFILLS WITH FILLER PORT UPGRADE
- 60LITRE ALLY WATER TANK AND PUMP SETUP—NON DRINKING
- 800 WIDE ALUMINIUM CANOPY
- 85LITRE UPRIGHT BUSHMAN FRIDGE
- LARGE STORAGE COMPARTMENT
- DOUBLE SEALED DOORS
- LED MAXILAMP TAILLIGHTS W/ REVERSE FLOODLIGHTS
- SENSOR AND CAMERA ADAPTABILITY
- WHALE TAIL COMPRESSION LOCKS
- ELEMENT BLACK TEXTURE POWDER COAT, SATIN BLACK CNC PLATING
- HOSE FITTING INLET/OUTLET WATER TANK POINTS
- PROWIRE 12V SOLUTION - PACKAGE A—ESSENTIALS

\$24,995 inc gst—drive away

Add accessories from our list of upgrades to personalise your build



CROOKED RIVER SERIES

Signature Models

The Weekender 12v & Options

Package A - Essentials - STANDARD INCLUSION

- Enerdrive ePower 40A DC-DC Charger
- 150Ah Slimline AGM Battery
- Enerdrive OLED Voltmeter
- 2 x Enerdrive 12v Accessory Sockets
- 2 x Enerdrive OLED Twin USB Sockets
- Enerdrive Flushmount 12 way Fusebox
- Anderson Plug Solar Input
- Hard Korr White/Amber 250mm LED
- Door Lights with Dimmer Switches

Package B - Elements - ADD \$2150 inc GST

- Enerdrive ePower 40A DC-DC Charger
- Enerdrive BTEC 100Ah Slimline Lithium Battery
- Enerdrive ePro Plus Battery Monitor
- 2 x Enerdrive 12v Accessory Sockets
- 2 x Enerdrive OLED Twin USB Sockets
- Enerdrive Flushmount 12 way Fusebox
- Anderson Plug Solar Input
- Hard Korr White/Amber 250mm LED
- Door Lights with Dimmer Switches

Package C - Extreme - ADD \$4720 inc GST

- Enerdrive ePower 40A DC-DC Charger
- Enerdrive BTEC 100Ah Slimline Lithium Battery
- Enerdrive ePro Plus Battery Monitor
- Enerdrive 1000w Inverter with Remote
Switch & Powerboard
- 2 x Enerdrive 12v Accessory Sockets
- 2 x Enerdrive OLED Twin USB Sockets
- 2 x Enerdrive OLED Temperature Sockets - Fridge &
Freezer Temperatures
- Enerdrive OLED Voltmeter
- Enerdrive Flushmount 12 way Fusebox
- Anderson Plug Solar Input
- Anderson Plug 12v Output
- Hard Korr White/Amber 250mm LED
- Door Lights with Dimmer Switches
- Canopy Central Locking

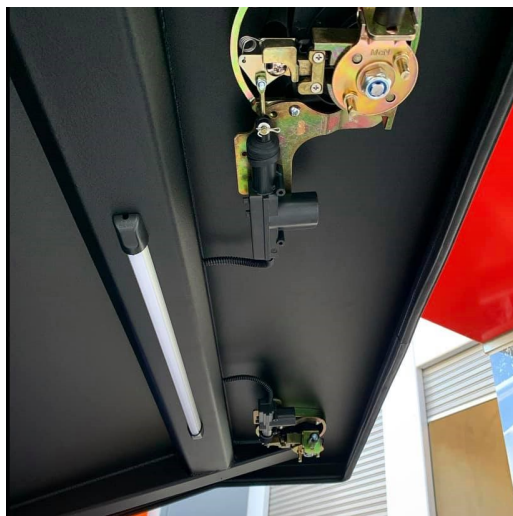

CROOKED RIVER SERIES

Signature Models

The Getaway

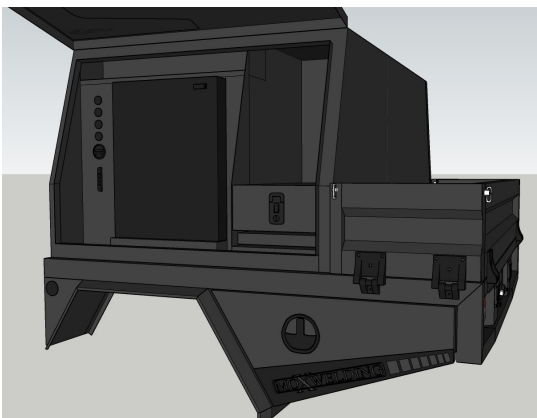
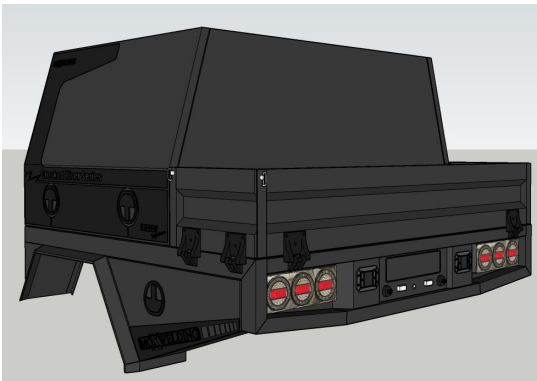
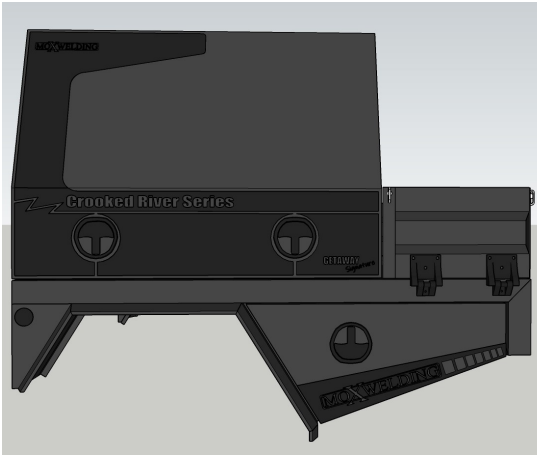

- ALUMINIUM BASE TRAY 1700L x 1800W
- 3MM RAW ALUMINIUM CHECKER PLATE FLOOR
- TRAY DROP SIDES
- ANTI RATTLE TRAY SIDE LATCHES
- HEAVY DUTY ABS PLASTIC NO RUST NO RATTLE TRAY SIDE HINGES
- INTERNAL TRAY TIE DOWN TRACK POINTS
- SIDE TAPERED TOOLBOXES
- FLARED ALUMINIUM GUARDS 50mm
- ALUMINIUM INFILLS WITH FILLER PORT UPGRADE
- 60LITRE ALLY WATER TANK AND PUMP SETUP—NON DRINKING
- 1200 WIDE ALUMINIUM CANOPY
- 85LITRE UPRIGHT BUSHMAN FRIDGE
- KITCHEN BENCH & DRAWER COMBO UNIT
- LARGE STORAGE COMPARTMENT
- DOUBLE SEALED DOORS
- LED MAXILAMP TAILLIGHTS W/ REVERSE FLOODLIGHTS
- SENSOR AND CAMERA ADAPTABILITY
- WHALE TAIL COMPRESSION LOCKS
- ELEMENT BLACK TEXTURE POWDER COAT, SATIN BLACK CNC PLATING
- HOSE FITTING INLET/OUTLET WATER TANK POINTS
- PROWIRE 12V SOLUTION—PACKAGE A - ESSENTIALS

\$29,445 inc gst—drive away



Add accessories from our list of upgrades to personalise your build

CROOKED RIVER SERIES

Signature Models

The Getaway 12v & Options

Package A - Essentials - STANDARD INCLUSION

- Enerdrive ePower 40A DC-DC Charger
- Enerdrive BTEC 100Ah Slimline Lithium Battery
- Enerdrive ePro Plus Battery Monitor
- Enerdrive Lithium Reset Button
- 2 x Enerdrive 12v Accessory Sockets
- 2 x Enerdrive OLED Twin USB Sockets
- Enerdrive Flushmount 12 way Fusebox
- Anderson Plug Solar Input
- Hard Korr White/Amber 480mm LED Door Lights with Dimmer Switches

Package B - Elements - ADD \$2190 inc GST

- Enerdrive ePower 40A DC-DC Charger
- Enerdrive BTEC 100Ah Slimline Lithium Battery
- Enerdrive ePro Plus Battery Monitor
- Enerdrive 1000w Inverter with Remote Switch & Powerboard
- 2 x Enerdrive 12v Accessory Sockets
- 2 x Enerdrive OLED Twin USB Sockets
- Enerdrive Flushmount 12 way Fusebox
- Anderson Plug Solar Input
- Hard Korr White/Amber 480mm LED Door Lights with Dimmer Switches

Package C - Extreme - ADD \$4750 inc GST

- Enerdrive ePower 40A DC-DC Charger
- Enerdrive BTEC 200Ah Lithium Battery
- Enerdrive ePro Plus Battery Monitor
- Enerdrive 2000w Inverter with Remote Switch & Powerboard
- 2 x Enerdrive 12v Accessory Sockets
- 2 x Enerdrive OLED Twin USB Sockets
- 2 x Enerdrive OLED Temperature Sockets -
Fridge & Freezer Temperatures
- Enerdrive OLED Voltmeter
- Enerdrive Flushmount 12 way Fusebox
- Anderson Plug Solar Input
- Anderson Plug 12v Output
- Hard Korr White/Amber 480mm LED
Door Lights with Dimmer Switches
- Canopy Central Locking

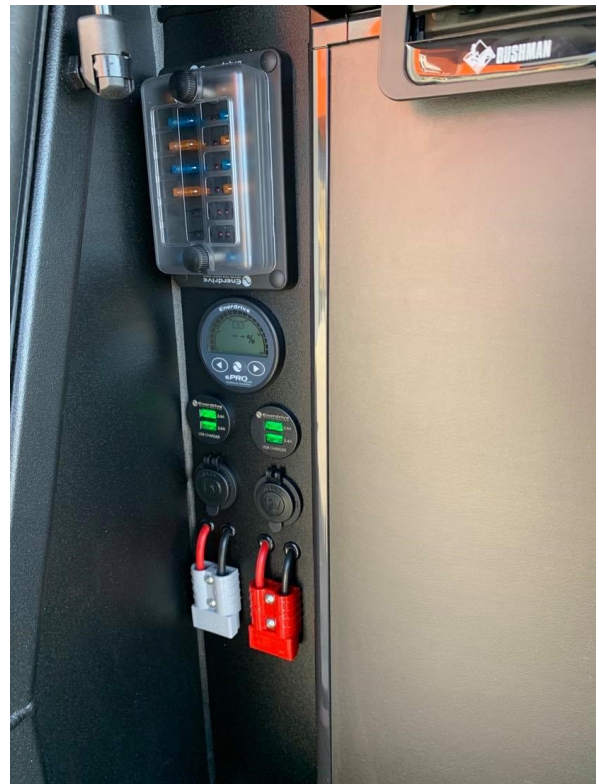

PROWIRE
AUTO⚡ELECTRICS

CROOKED RIVER SERIES

Signature Models

The Breakout

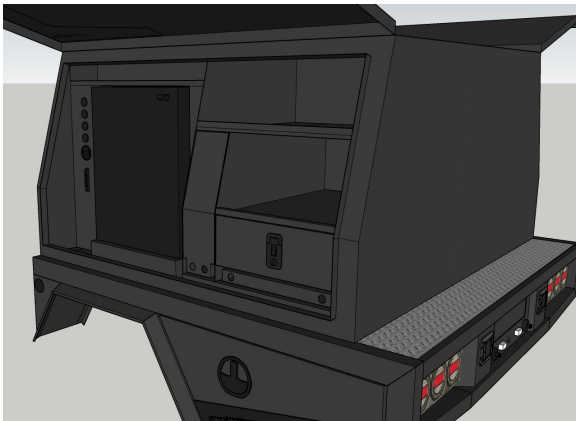
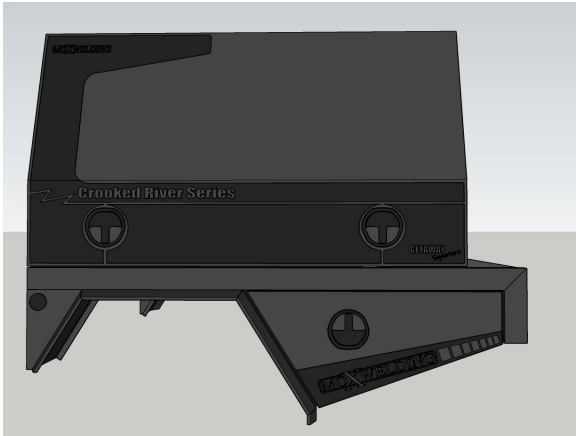

- ALUMINIUM BASE TRAY 1700L x 1800W
- 3MM RAW ALUMINIUM CHECKER PLATE FLOOR REAR SECTION
- UPGRADED FILLER PORT
- SIDE TAPERED TOOLBOXES
- FLARED ALUMINIUM GUARDS 50mm
- ALUMINIUM INFILLS WITH FILLER PORT UPGRADE
- 60LITRE ALLY WATER TANK AND PUMP SETUP—NON DRINKING
- 1500 WIDE ALUMINIUM CANOPY
- 85LITRE UPRIGHT BUSHMAN FRIDGE
- SLIDE OUT PANTRY
- KITCHEN BENCH & DRAWER COMBO UNIT
- LARGE STORAGE COMPARTMENT
- DOUBLE SEALED DOORS
- LED MAXILAMP TAILLIGHTS W/ REVERSE FLOODLIGHTS
- SENSOR AND CAMERA ADAPTABILITY
- WHALE TAIL COMPRESSION LOCKS
- ELEMENT BLACK TEXTURE POWDER COAT, SATIN BLACK CNC PLATING
- HOSE FITTING INLET/OUTLET WATER TANK POINTS
- PROWIRE 12V SOLUTION—PACKAGE A - ESSENTIALS

\$32,995 inc gst—drive away
K9 MODEL UPGRADE—\$2100



Add accessories from our list of upgrades to personalise your build

CROOKED RIVER SERIES

Signature Models

The Breakout 12v & Options

Package A - Essentials - STANDARD INCLUSION

- Enerdrive ePower 40A DC-DC Charger
- Enerdrive BTEC 100Ah Slimline Lithium Battery
- Enerdrive ePro Plus Battery Monitor
- Enerdrive Lithium Reset Button
- 2 x Enerdrive 12v Accessory Sockets
- 2 x Enerdrive OLED Twin USB Sockets
- Enerdrive Flushmount 12 way Fusebox
- Anderson Plug Solar Input
- Hard Korr White/Amber 1000mm LED Door Lights with Dimmer Switches

Package B - Elements - ADD \$2190 inc GST

- Enerdrive ePower 40A DC-DC Charger
- Enerdrive BTEC 100Ah Slimline Lithium Battery
- Enerdrive ePro Plus Battery Monitor
- Enerdrive Lithium Reset Button
- Enerdrive 1000w Inverter with Remote Switch & Powerboard
- 2 x Enerdrive 12v Accessory Sockets
- 2 x Enerdrive OLED Twin USB Sockets
- Enerdrive Flushmount 12 way Fusebox
- Anderson Plug Solar Input
- Hard Korr White/Amber 1000mm LED Door Lights with Dimmer Switches

Package C - Extreme - ADD \$4750 inc GST

- Enerdrive ePower 40A DC-DC Charger
- Enerdrive BTEC 200Ah Lithium Battery
- Enerdrive ePro Plus Battery Monitor
- Enerdrive Lithium Reset Button
- Enerdrive 2000w Inverter with Remote Switch & Powerboard
- 2 x Enerdrive 12v Accessory Sockets
- 2 x Enerdrive OLED Twin USB Sockets
- 2 x Enerdrive OLED Temperature Sockets - Fridge & Freezer Temperatures
- Enerdrive OLED Voltmeter
- Enerdrive Flushmount 12 way Fusebox
- Anderson Plug Solar Input
- Anderson Plug 12v Output
- Hard Korr White/Amber 1000mm LED Door Lights with Dimmer Switches
- Canopy Central Locking



PROWIRE

AUTO⚡ELECTRICS



CROOKED RIVER SERIES

Signature Models

UPGRADES

ALL PRICING EXCLUDING GST UNLESS STATED

- Flat roof rack - \$765 - additional solar recess and bracketry - add \$150
- Locking lid jerry / storage holder - \$385
- Overhead firearm/storage locker - \$695
- Rear access ladder - \$385 - Folding add \$275
- Spare wheel mount - \$220
- Rear bolt down hurdle - \$385
- Awning brackets vary product dependant - enquire
- Dog door cutout and canvas cover panel - weekender unit only - \$595
- **K9 UPGRADE FOR BREAKOUT**— additional dog box division - door cutout with canvas cover panel—additional lighting and central locking wiring provisions—additional powder coating- breakout model only - \$2100 INC GST
- Additional drawer units - drivers side only - getaway & breakout models only
GETAWAY 2 piece—\$1395 - BREAKOUT 3 piece - \$1995
- Unique Colour Schemes — enquire
- Rooftop Tent - Bush Company Alpha (AX27) - inc fitting cost— \$6450 as of 1/3/22 (price subject to vary)
- Central locking added to essential and elements wiring packages - \$655
- Enerdrive ePRO plus Bluetooth module - \$235
- 100w Enerdrive Solar Panel - Roofrack mounted - All models - \$470 add \$130 for Tent mounting
- 150w Enerdrive Solar Panel - Roofrack mounted - Getaway & Breakout Only - \$560 add \$130 for tent mounting
- 240w Enerdrive Portable Folding Solar Panel - \$899
- 200w Hard Korr Lifestyle Portable Solar Blanket - \$379
- Rear view system - Gator 1080P Wideview Clipover Monitor with Butterfly Camera - under tray mount - \$599
- Rear view system - Safety Dave 7" Clipover monitor system with HD Camera - canopy mounted—only for models without rear spare wheel mount - \$825
- Hard Korr Hyper Flood rear LED work/camp lights -centre mounted or no spare wheel only - \$435
- External Anderson Plug with cover for RTT Power - \$164
- ARB Twin Compressor fitted in undertray toolbox - \$1320

Further 12v Services Available - \$POA

- UHF Radios - GME & Uniden— Driving Lights & Lightbars - UltraVision, Narva, LightForce, Hard Korr
- Electric Brake Controller & Towing Packages
- 12v Winches - Runva—GPS Tracking Systems

The logo features a stylized mountain range with a lightning bolt on the left. To the right, the text "CROOKED RIVER SERIES" is written in a bold, black, sans-serif font. Below this, the words "Signature Models" are written in a large, white, cursive script font, set against a black horizontal bar.

CROOKED RIVER SERIES

Signature Models

Additional Information & Queries

Why don't the signature models feature a rear trundle drawer?

At moxwelding Offroad solutions we like to factor in every element of design to reach an overall build quality that isn't flawed by unnecessary accessories and weight distribution. We don't build to suit purely suit current trends. Our solutions must be both practical and aesthetically pleasing. Not only does your new build need to make your camping and touring experience much more enjoyable, it also has to handle and perform safely and comfortably both on and Offroad.

- **WEIGHT FACTOR**

With building a strong, dust and water proof trundle drawer comes a serious weight factor. An empty 1200 deep drawer unit will weigh roughly 55kg. Placing this additional weight, plus additional weight of contents, at the rear of a vehicle can seriously affect the driving and handling, not to mention adding to GVM complications in regards to total build weight and additional storage weight.

- **SIZE LIMITATIONS**

When building drawer units housed under our trays, we are limited by factors such as bottom of tray to highest point of chassis crossmembers and other component mounts. These factors limit the height we can build our drawer housing which severely affects the depth of the internal slide out drawer. Unless we lift the tray and canopy unit much higher than usual, we normally end up with a drawer that is no deeper than 100mm.

- **COST EFFICIENCY**

It takes a lot of labour and materials to properly build a well sealed trundle drawer. When comparing cost against factors such as additional weight and actual usable space, we find the negatives far outweigh the minimal benefits. With many other options for storage space available, it was a very quick decision to not include them with any of our signature models

What is the warranty specifics with a Moxwelding Signature build?

Moxwelding is a company that stands behind its products.

Moxwelding product warranty - all moxwelding manufacturing and fitting criteria covered by lifetime warranty. Lifetime warranty must be met with regular service, maintenance, and inspection. Warranty does not cover general wear and tear from constant Offroad and harsh usage conditions. Modification and adaptation may result in voidance of warranty.

Component and fittings warranty—all components and fittings have different manufacture warranty ranging from 12 months minimum.

Electrical warranty—fitting and installation covered in full. Individual component warranty determined by manufacturer and detailed in all component booklets

Powder and Coatings warranty— We don't take any shortcuts when it comes to the necessary steps to ensure the ultimate bonding and coating quality on our products. All coatings are covered by a lifetime warranty for severe lifting or separation. Due to the harsh nature of our operating conditions, scratches, scrapes, chipping, scuffing, and other surface integral damage factors can not be covered. Cleaning and detailing must be carried out with light duty detergents and hot water only. Chemical use will void any warranty.

CROOKED RIVER SERIES

Signature Models

Additional Information & Queries

Rear sensors, camera's

Moxwelding will relocate reverse cameras and sensors, however as they are fitted into a non-factory position, they may operate a little different to original setting. Cameras are positioned as best as possible for clear vision.



Upgraded fuel filler

Moxwelding upgrades the filler inlet to a flush mount filler port with integrated breather. Due to the lower relocation of fillers from tub to tray installation, you may experience some 'clicking' depending on how the pumps are set up to flow at each station. Rotating the filler nozzle to find the perfect alignment will overcome this issue.



Hi-Flow pumps are not recommended for non-commercial vehicles. Fuel delivery from these pumps is of a much higher flow rate and will exceed many vehicle fuel venting systems resulting in fuel surging back out of the filler port. We design our filler systems for regular flow pumps only.

Tub or existing tray removal

Removal of factory tubs are charged at \$275inc. This covers time involved in removal, storage and disposal requirements. For customers wanting to keep their tub, we suggest prior removal before delivery of vehicle at our premises. Vehicles can be legally delivered as cab chassis providing tail lights are in working order (cable tie to rear), and tyres are covered (simple sheet of ply over top of tyres), registration plate clearly visible. Transport is also another option and we can help to organize at competitive rates. Moxwelding takes no responsibility for any damage of tubs upon removal.

Suspension Upgrade / GVM concerns

Moxwelding highly recommends talking to us before hand to determine a suspension solution prior to installation. We can give an accurate weight guide for your build, and with factoring in other aspects such as additional loading/towing we can help to get you fitted with the suspension you require. A GVM upgrade may be recommended on most makes and models to ensure legal touring on your adventures.



Dust and Water proofing

You may have noticed we build our doors differently to many other manufacturers. Not only does this give us a completely smooth and border free outer face, it gives us the ability to design a canopy with a complete gutter system that comprises a large dust seal along with another dust seal attached to the adjoining door. Essentially becoming a double seal, we find it helps to eliminate any dust and water ingress over time due to general softening/wear of seals, and failure to adjust door lock compression. We don't fit air vents as these can assist in water, dirt, dust, bug ingress over time.

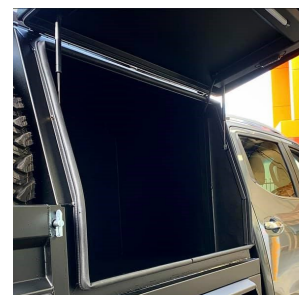

CROOKED RIVER SERIES

Signature Models

Additional Information &

Custom colours

All Moxwelding builds are finished in element black textured powdercoat. We find this to be an extremely durable and aesthetically pleasing colour. For custom finishes we offer paint match/customized colours on our tray and canopy doors only.



Can I fit the build on another vehicle?

Moxwelding builds all units to perfectly fit each manufacturer's vehicle models. Mounts are designed and made to suit vehicle specifics. All vehicles have different dimensions relating to axle location and chassis widths which affects tray guard location, side toolbox sizing, mount and rail locations. If upgrading your vehicle to a newer model (hilux to hilux, ranger to ranger) the unit can be a direct swapover.

Can I fit a rooftop tent to my build?

Moxwelding recommends Bush Company alpha rooftop tents and the Darche ridgeback tents. These tents are fitted by us with our dedicated mounting systems. Other brand tents can be fitted to all models with the inclusion of our flat rack.



Are my 12v accessories easily accessed?

All 12v accessories that require normal use are placed in easily accessible locations ready to use. Any item such as DC charger, inverters, fusing, batteries are placed securely and out of sight in our fridge cavity to avoid tampering and damage. All cabling is run through closed channels and paths free from interference and damage.

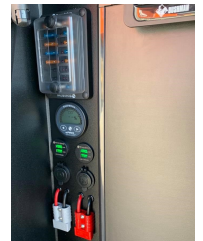

Can I get a "jack off" canopy?

We made the decision to stop building "jack off" style canopies due to the fact that approx. 95% of our customers that purchased one found out quite quickly it's not as versatile as it appears and they rarely/never used the "jack off" system again. Door openings are significantly decreased to allow for leg inserts which takes away from the internal usability. The added costs and weight from materials including quality jacking legs are significant. The idea of touring and leaving your canopy at a caravan park requires taking the large, heavy, and protrusive legs along for the journey which takes crucial space away from necessary items. All wiring must be plug and play which adds to cost. Another factor is that the tray now requires a full floor and headboard for cabin protection once canopy is removed, adding once again more cost and weight.



For any further enquiries, to make a booking, or request an official quote, please get in contact with us today!

CROOKED RIVER SERIES *Signature Models*

GALLERY



CROOKED RIVER SERIES

Signature Models

GALLERY

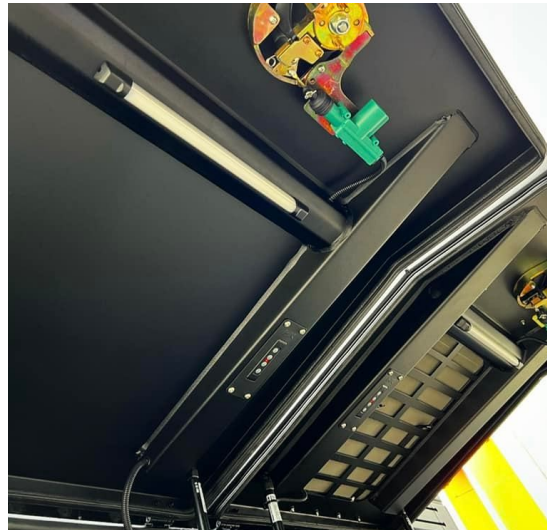



MOX WELDING

OFFROAD SOLUTIONS

30a Tarmac Way Pakenham Vic 3810

moxwelding@hotmail.com

Workshop hours: 8-4pm Monday –Friday

Closed public holidays